

- Approval Condition: This Plan Sanction is issued subject to the following conditions: 1. Sanction is accorded for the Residential Building at 24, THIMMA REDDY COLONY, Bangalore. 2. Existing is accorded for Residential use only...

COLOR INDEX table with color-coded boxes for Plot Boundary, Abutting Road, Proposed Work, Existing, and Demolished.

AREA STATEMENT (BBMP) and PROJECT DETAIL table containing project information, area details, and FAR check.

Approval Date : 10/02/2019 2:40:01 PM

Payment Details

Payment Details table with columns for Sr No, Challan Number, Receipt Number, Amount, Payment Mode, Transaction Number, Payment Date, and Remark.

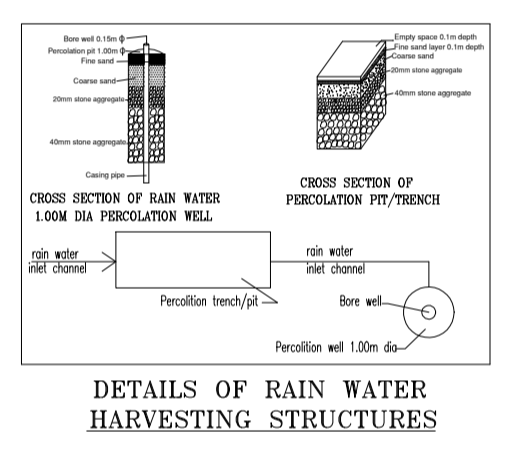
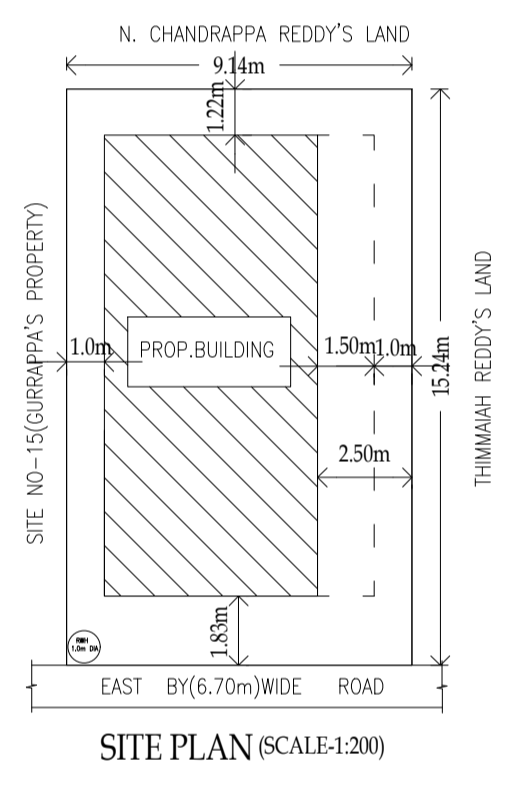
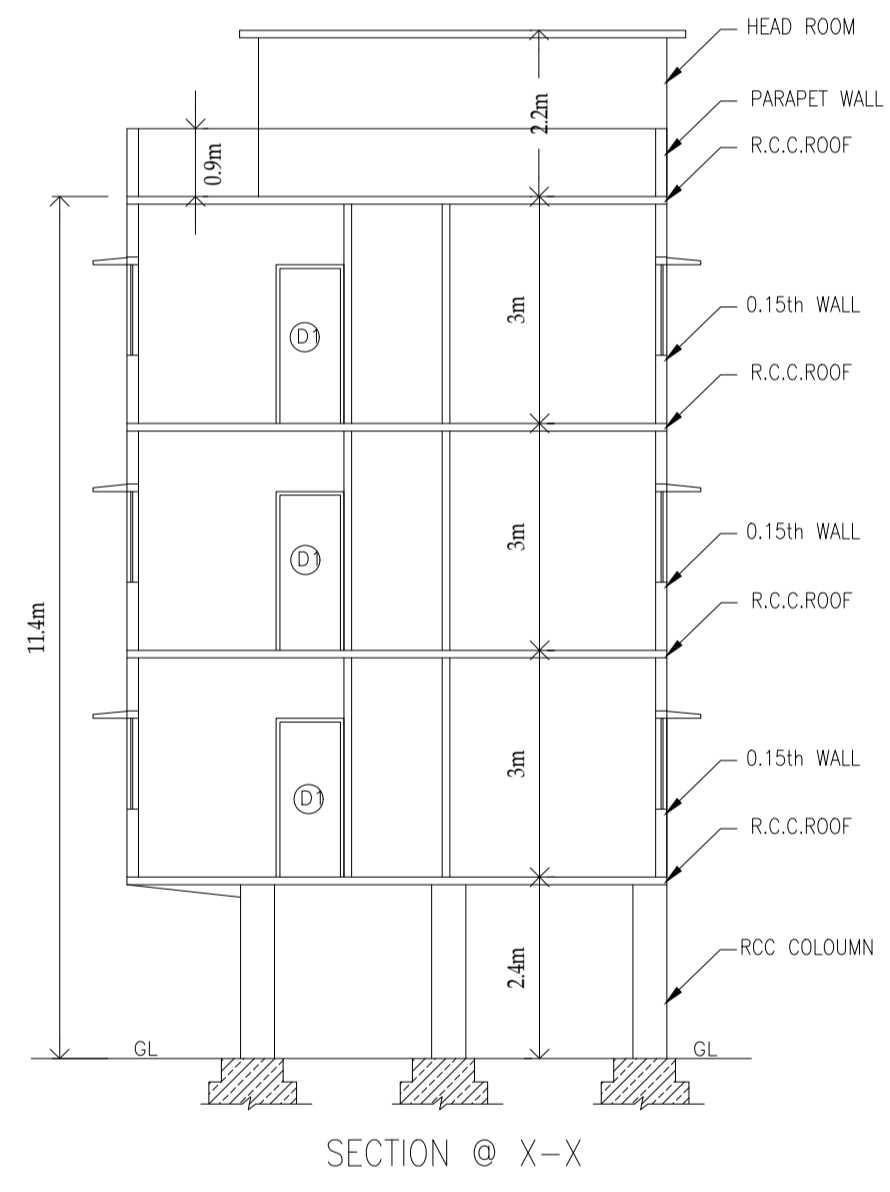
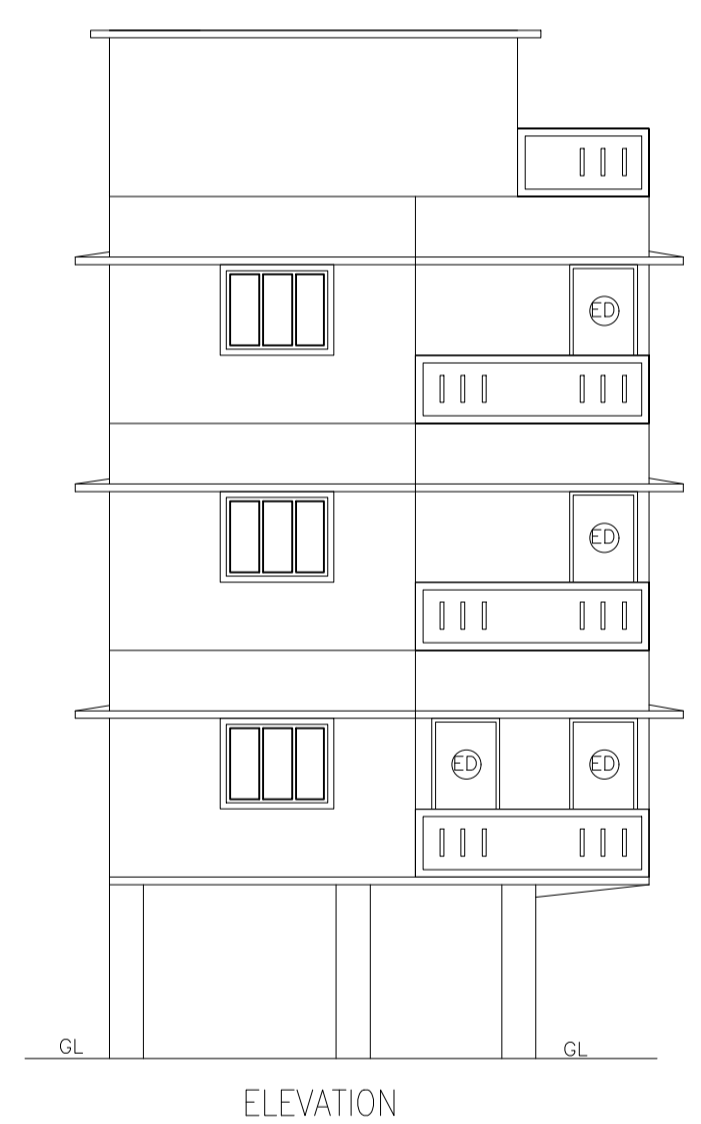

- 1. Registration of Applicant / Builder / Owner / Contractor and the construction workers working in the construction site with the 'Karnataka Building and Other Construction workers Welfare Board' should be strictly adhered to. 2. The Applicant / Builder / Owner / Contractor should submit the Registration of establishment and list of construction workers engaged at the time of issue of Commencement Certificate...

Block :A (GUPTA)

Table with columns: Floor Name, Total Built Up Area (Sq.mt.), Deductions (Area in Sq.mt.), Proposed FAR Area (Sq.mt.), Total FAR Area (Sq.mt.), and Trmt (No.).

SCHEDULE OF JOINERY:

Table with columns: BLOCK NAME, NAME, LENGTH, HEIGHT, NOS.

SCHEDULE OF JOINERY:

Table with columns: BLOCK NAME, NAME, LENGTH, HEIGHT, NOS.

UnitBUA Table for Block :A (GUPTA)

Table with columns: FLOOR, Name, UnitBUA Type, UnitBUA Area, Carpet Area, No. of Rooms, No. of Tenement.

Required Parking (Table 7a)

Table with columns: Block Name, Type, SubUse, Area (Sq.mt.), Units, Car, Prop., Req'd./Unit, Req'd., Prop.

Parking Check (Table 7b)

Table with columns: Vehicle Type, No., Area (Sq.mt.), No., Area (Sq.mt.).

FAR & Tenement Details

Table with columns: Block, No. of Same Bldg, Total Built Up Area (Sq.mt.), Deductions (Area in Sq.mt.), Proposed FAR Area (Sq.mt.), Total FAR Area (Sq.mt.), Trmt (No.).

Block USE/SUBUSE Details

Table with columns: Block Name, Block Use, Block SubUse, Block Structure, Block Land Use Category.

UnitBUA Table for Block :A (GUPTA)

Table with columns: FLOOR, Name, UnitBUA Type, UnitBUA Area, Carpet Area, No. of Rooms, No. of Tenement.

The plans are approved in accordance with the acceptance for approval by the Assistant Director of town planning (EAST (C)) on date: 02/10/2019 vide Ip number: BBMP/Ad.Com./EST/0752/19-20 subject to terms and conditions laid down along with this building plan approval.

Validity of this approval is two years from the date of issue.

Name : ASHA B S Designation : Assistant Director Town Planning (ADTP) Organization : BRUHAT BANGALORE MAHANAGARA PALIKE Date : 23-Oct-2019 11:46:58

ASSISTANT DIRECTOR OF TOWN PLANNING (EAST (C)) BRUHAT BENGALURU MAHANAGARA PALIKE

OWNER / GPA HOLDER'S SIGNATURE

OWNER'S ADDRESS WITH ID NUMBER & CONTACT NUMBER : Sri. D.L. NANJUNDA GUPTA THIMMA REDDY COLONY, KONENA AGRAHARA KONENA AGRAHARA

ARCHITECT/ENGINEER /SUPERVISOR 'S SIGNATURE

MALLU MADHUSUDHAN REDDY #2 LEVEL 2, SB COMPLEX, NEXT TO I HMT MAIN ROAD, MATHIKERE. BCC/BL-3.6/E-4003/2014-1

PROJECT TITLE : PLAN SHOWING THE PROPOSED RESIDENTIAL BUILDING AT, SITE NO- 24, THIMMA REDDY COLONY, 2nd CROSS, AIRPORT, KONENA AGRAHARA, BANGALORE, WARD NO-113(73). P.I.D NO- 73-26-24.

DRAWING TITLE : 1761500440-19-09-2019 08-13-45\$ \$NANJUNDA GUPTHA

SHEET NO : 1